

# A Study of the Straw Tube Detector for the GlueX Detector at Jefferson Lab

Mike Williams, Zebulun Krahn and Curtis A. Meyer

July 26, 2002

## **Abstract**

Detector sensitivity is crucial for detailed analysis looking for exotic mesons states through partial wave analysis. To help determine optimal sensitivity dynamic signal range must be determined for the various types of measurements to be done with the detector.

# 1 Introduction

The Thomas Jefferson National Accelerator Facility (JLAB) in Newport News, VA is a new facility that is utilizing high energy electron and photon beams to study the structure of nuclear matter. JLAB is currently planning to double the energy of its accelerator with the main physics emphasis on experiments to try and explain why the constituents which build the protons and neutrons (quarks) are forever confined inside their parent particle. This particular question has been listed in the New York Times as one of the most important scientific questions of the new millennium. To attack this problem, an international group of physicists has come together to build a entirely new beam line and detector at the lab, known as Hall D. Carnegie Mellon is currently one of the leading institutions on this \$35,000,000 detector. The current plan is to be able to start taking data with this detector in early '2009.

The goal of this study is to examine signals generated in a strawtube chamber that is similar in tube-design to that planned in the GlueX experiment. The chamber is part of the former EVA experiment at Brookhaven and has been given to CMU. Signals were generated using a highly collimated  $^{106}\text{Ru}$  source, and coincidences were recorded on the four layers of the existing chamber. The signals were studied using two different gas mixtures, and several different voltage settings on eh chamber. A good understanding of the dynamic range of the signals is needed to properly design the electronics to be used on the chamber.

## 1.1 Description/Procedure

The EVA chamber consists of 2m long straw tubes each with diameter of 2.088cm. The cathode wire is a resistive wire that is nominally read out at both ends, and through charge division, the position in 'z' can be determined. (The GlueX experiment plans to accomplish this using stereolayers). The chamber has four layers of tubes, with 16 tubes in each layer. The electronics is blocked into 8 groups of tubes, with two tubes from each layer in each group (see Figure 1).

To determine the dynamic ranges of the measurements involved, we utilized one block of eight tubes. We then concentrated on one set of four tubes which are read out by a pre-amplifier card. A cross-sectional diagram of a set of eight tubes is given in Figure 1. We selected four adjacent tubes, linearly aligned, as our detector, in this case we used tubes 2,4,6 and 8. We read the signals from the chamber through the pre-amplifier and record them with a Tektronix 4-channel digital oscilloscope. A collimated  $\beta$  source,  $^{106}\text{Ru}$ ,

placed at a crossing angle of 90 degrees was used to keep the flux of particles through the chamber fairly consistent while the experiment was running.

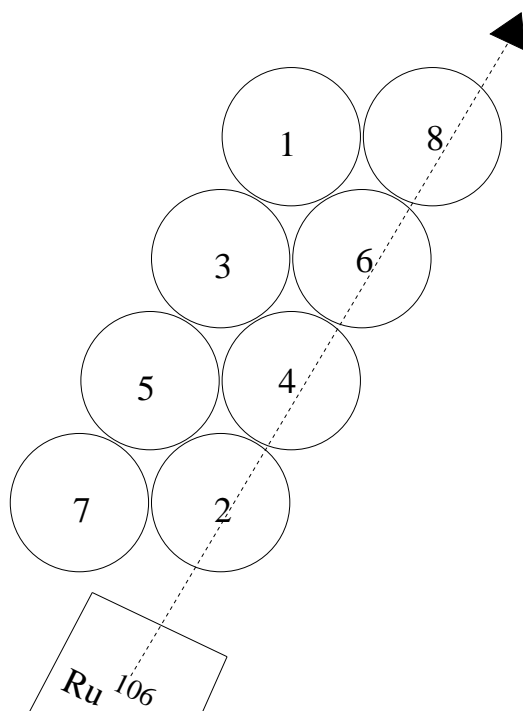

Figure 1: Diagram of Strawtubes and associated numbers.

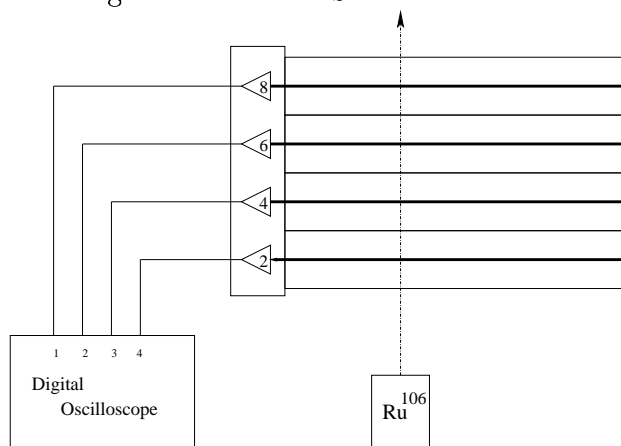

Figure 2: Diagram of strawtube and oscilloscope set up.

Data was taken by triggering off of the signal in tube 8 and recording coincident signals in all 4 tubes. These recorded signals were then analyzed for signal threshold, maximum peak height (with the threshold subtracted out), pulse length, and the integral value of the pulse (also with threshold subtracted out) using a C++ program written for the analysis. Data was

acquired under several sets of conditions. First, the experiment was run with a 90/10 Argon-Carbon-dioxide ( $Ar - CO_2$ ) gas mixture and the voltage on the tubes was varied from 1700V to 1850V in 50V increments. Then, the composition of the gases in the chamber was changed to a 50/50 Argon-Ethane ( $Ar - C_2H_6$ ) mixture. Data was taken at 2050V and 2100V.

## 2 Results

### 2.1 Signals Demonstrating Coincidence

The signals recorded varied in shape and amplitude with the differing voltages and gas mixtures. Examples of signals with the  $Ar - CO_2$  can be seen in Figure 3, and examples with the  $Ar - C_2H_6$  are in Figure 4. It is important to note that only signals that demonstrated coincidence in all 4 tubes were recorded for analysis. Note that on average, the  $Ar - CO_2$  signals had longer tails than the signals from the  $Ar - C_2H_6$  mixture, though the leading pulses appear very similar in shape and size.

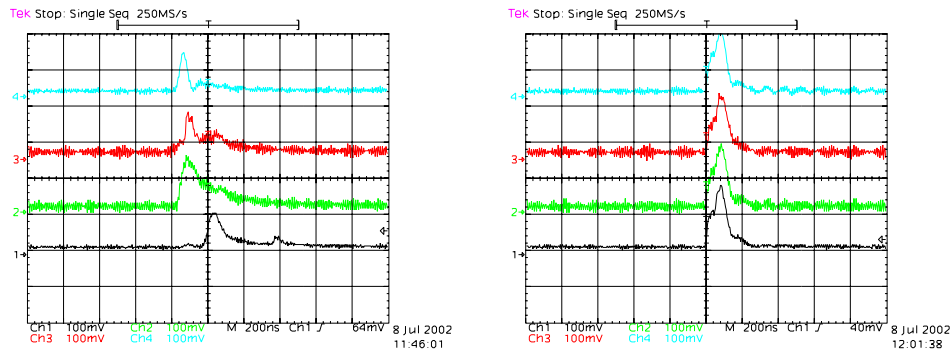

Figure 3: Samples of 4 channel coincidence with  $Ar - CO_2$  at 1800V in 100mV per square scale with time scale of 200 ns per square.

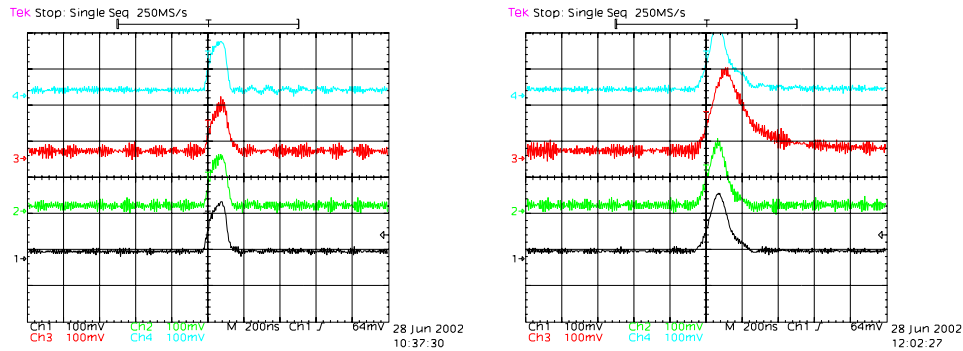

Figure 4: Samples of the signals from the chamber indicating 4-channel coincidence with the  $Ar - C_2H_6$  gas mixture at 2050V in 100mV per square scale.

## 2.2 Threshold Measurements

The 1800V data with the  $Ar - CO_2$  gas mixture was also subjected to a tube by tube analysis. This analysis allowed for further checks of consistency and reproducibility. While the threshold varied from tube to tube, once these threshold values were subtracted out, the data were consistent, which allowed us to combine the data from all four tubes. The threshold of each tube is independent of the high voltage settings.

## 2.3 Maximum Peak Height

The maximum height of each pulse with the threshold value subtracted out was binned into a histogram. As shown by Figure 5, the signal peak size increases with increasing voltage, as expected. Histograms of the peak minus threshold value for tested voltages of the 90/10  $Ar - CO_2$  gas mixture are in Figure 6. Histograms for the  $Ar - C_2H_6$  values are in Figure 7. From these distributions and the signal quality, it was determined that the optimal voltage for operation with the 90/10  $Ar - CO_2$  gas mixture was approximately 1800V. It is clear to see that when the voltage was increased beyond to 1850V the distribution broadened drastically and noise in the signals also increased. The optimal running voltage for the 50/50  $Ar - C_2H_6$  gas mixture was higher than the  $Ar - CO_2$  mixture at 2050V. Signals here were clean and the distributions reasonable. Data cited in the remainder of our report will be taken from experimental trials operating under these voltages.

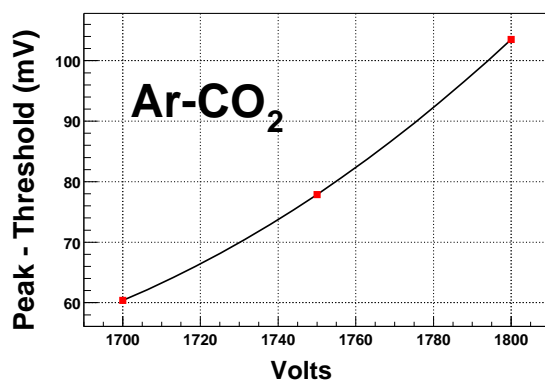

Figure 5: Graph of mean peak above threshold value versus voltage applied to tubes.

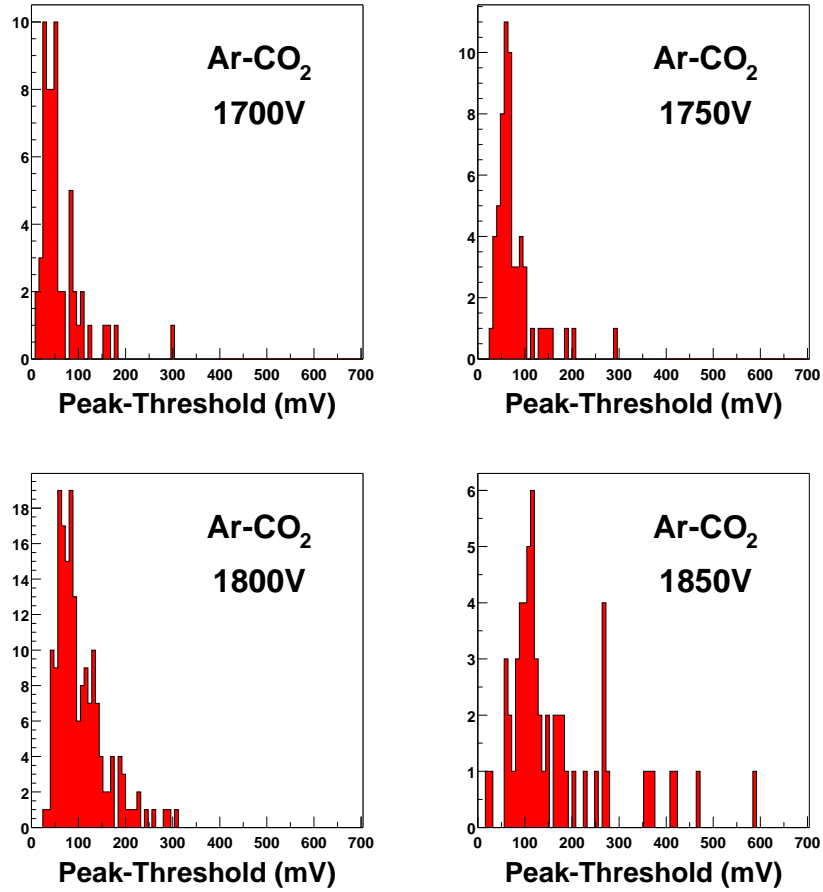

Figure 6: Maximum peak above threshold of signal for the  $Ar - CO_2$  gas mixture at measured voltages.

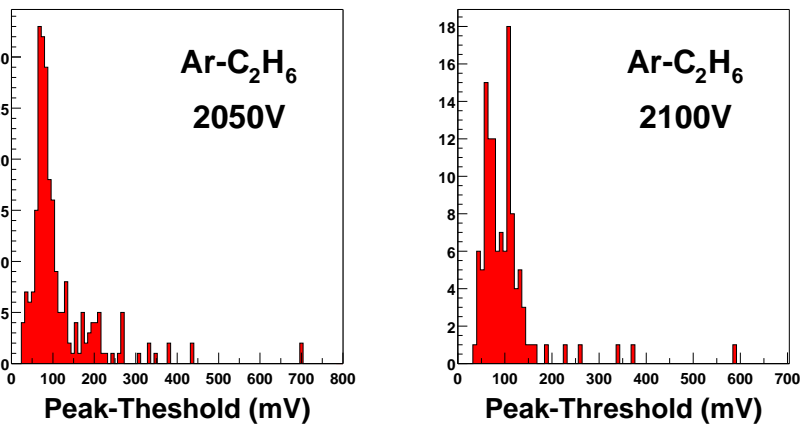

Figure 7: Maximum peak above threshold of signal at for 2050V and 2100V with  $Ar - C_2H_6$  gas mixture.

## 2.4 Pulse Length

The pulse length varied greatly depending upon the gas mixture used. The pulse length is defined by our analysis as the duration the signal is above 20 percent of its maximum value. The analysis does not require that the bins included be connected. The pulse length measured for the  $Ar - C_2H_6$  is more consistent with estimated drift times when the geometry of the tubes is taken into account. In this case, almost all of the recorded signals yielded a length that fell at or below 200ns. Whereas the distribution of the pulse lengths of the  $Ar - CO_2$  mixture seems to be broader, with many pulses extending beyond the 300ns mark. Figure 8 shows histograms of the pulse length values for the two gas mixtures.

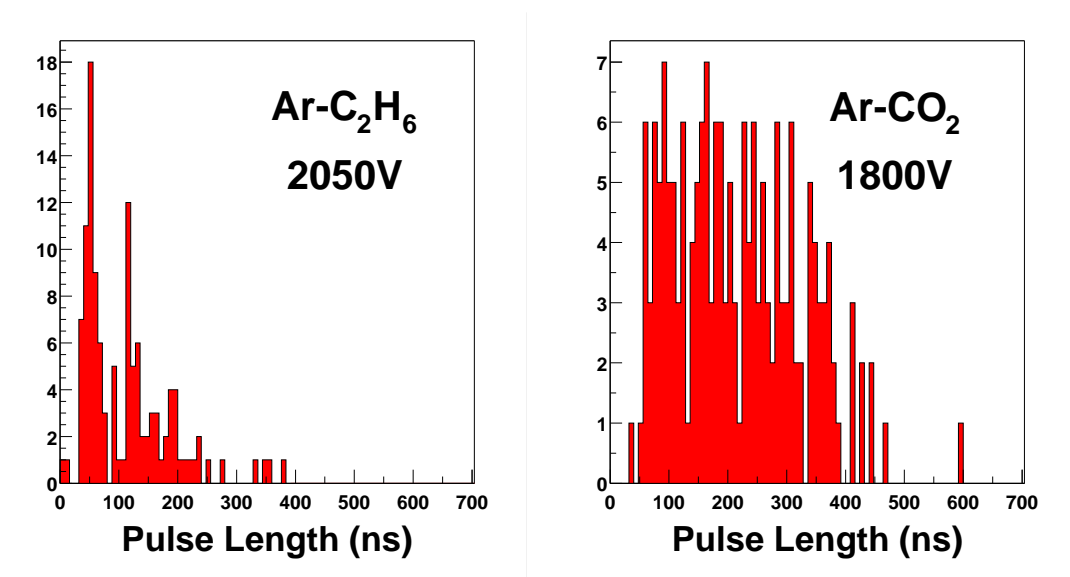

Figure 8: Pulse Length measurement for the two different gas mixtures at their respective optimal operating voltages.

## 2.5 Integral of Pulse

Since we are trying to define the dynamic range of the integral value a Riemann summing technique is used to calculate the integral values. Histograms of integral values (peak minus threshold) for both gas mixtures at their optimal operating voltages are shown in Figure 9. The distribution for the  $Ar - C_2H_6$  and is more sharply peaked than the distribution for the  $Ar - CO_2$  mixture. The peaks appear below the 10 V-ns mark in both cases, and the distribution of the signals extends out to 30V-ns. Note the integral values of the  $Ar - C_2H_6$  are suppressed due to shorter pulse length in comparison to the  $Ar - CO_2$  values.

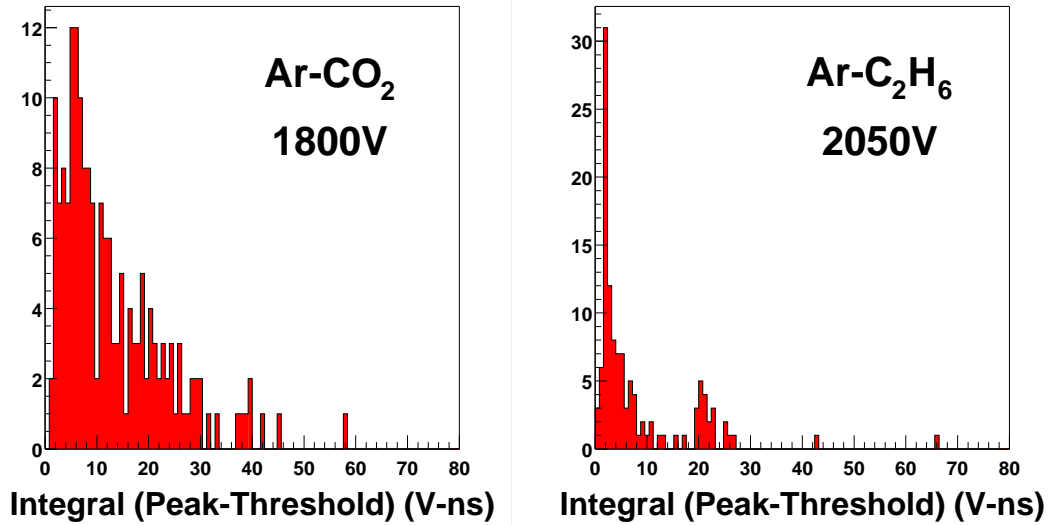

Figure 9: Distribution of pulse integral values for the different gases at their respective optimal operating voltages.

## 3 Conclusions

It has been determined that the signal quality is better and more consistent with the  $Ar - C_2H_6$  gas mixture operating at around 2050V. Further studies can to be made to determine what the optimal gas mixture is for this chamber. Dynamic ranges for the various types for data have been given within the parameters of our experiment.